



FOR YOUR SAFETY

**READ AND UNDERSTAND THE ENTIRE MANUAL
BEFORE OPERATING MACHINE**



SERIAL NUMBER : _____

Both model number and serial number may be found on the main label .
You should record both of them in a safe place for future use.

Save This Manual for Future Reference

5 TON LOG SPLITTER – Owner's Manual

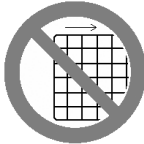
SAFETY WARNINGS & CAUTIONS

SAFETY WARNINGS & INSTRUCTIONS	SYMBOL AFFIXED TO THE MACHINE
<ul style="list-style-type: none">● UNDERSTAND YOUR LOG SPLITTER Read and understand the owner's manual and labels affixed to the log splitter. Learn its application and limitations as well as the specific potential hazards peculiar to it.● DRUGS, ALCOHOL AND MEDICATION Do not operate the log splitter while under the influence of drugs, alcohol, or any medication that could affect your ability to use it properly.● AVOID DANGEROUS CONDITIONS Put the log splitter on a 60 - 75cm high, stable, flat, and level work bench where there is plenty of room for handling, and help the operator stay alert. Bolt the log splitter to the work surface if it tends to slip, walk, or slide. Keep your work area clean and well lighted. Cluttered areas invites injuries. Do not use the log splitter in wet or damp areas or expose it to rain. Do not use it in areas where fumes from paint, solvents or flammable liquids pose a potential hazard.	
<ul style="list-style-type: none">● INSPECT YOUR LOG SPLITTER Check your log splitter before turning it on. Keep guards in place and in working order. Form a habit of checking to see that keys and adjusting wrenches are removed from tool area before turning it on. Replace damaged, missing or failed parts before using it.	
<ul style="list-style-type: none">● DRESS PROPERLY Do not wear loose clothing, gloves, neckties or jewelry (rings, wrist watches). They can be caught in moving parts. Protective electrically non conductive gloves and non-skid footwear are recommended when working. Wear protective hair covering to contain long hair, preventing it from get caught in machinery.	
<ul style="list-style-type: none">● PROTECT YOUR EYES AND FACE Any log splitter may throw foreign objects into the eyes. This can cause permanent eye damage. Always wear safety goggles. Everyday eyeglasses have only impact resistant lenses. They are not safety glasses. Do not put the log splitter on the ground for operations. This is awkward operating position that the operator has to bring his face close to the machine, and thus risks being struck by wood chips or debris.	

● EXTENSION CORDS

Improper use of extension cords may cause inefficient operation of the log splitter which can result in overheating. Be sure the extension cord is no longer than 10m and its section is no less than 2.5mm² to allow sufficient current flow to the motor.

Avoid use of free and inadequately insulated connections. Connections must be made with protected material suitable for outdoor use.

● AVOID ELECTRICAL SHOCK

Check that the electric circuit is adequately protected and that it corresponds with the power, voltage and frequency of the motor. Check that there is a ground connection, and a regulation differential switch upstream.

Ground the log splitter. Prevent body contact with grounded surfaces: pipes, radiators, ranges, and refrigerator enclosures.

Never open the pushbutton box on the motor. Should this be necessary, contact a qualified electrician.

Mark sure your fingers do not touch the plug's metal prongs when plugging or unplugging the log splitter.

● KEEP VISITORS AND CHILDREN AWAY

The log splitter must be always operated by one person only. Other people should keep a safe distance from the work area, especially when the log splitter is under operations. Never use another people to help you with freeing jammed log.

● INSPECT YOUR LOG

Make sure there are no nails or foreign objects in logs to be split. The ends of the logs must be cut square. Branches must be cut of flush with the trunk.

● DON'T OVERREACH

Floor must not be slippery.

Keep proper footing and balance at all times.

Never stand on log splitter. Serious injury could occur if the tool is tipped or if the cutting tools is unintentionally contacted. Do not store anything above or near the log splitter where anyone might stand on the tool to reach them.

● AVOID INJURY FROM UNEXPECTED ACCIDENT

Always pay full attention to the movement of the log pusher.

Do not attempt to load the log on until the log pusher has stopped.

Keep hands out of the way of all moving parts.

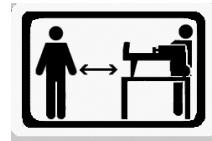

● **PROTECT YOUR HANDS**

Keep you hands away from splits and cracks which open in the log; They may close suddenly and crush or amputate your hands.

Do not remove jammed logs with you hands.



● **DON'T FORCE TOOL**

It will do a better and safer job at its design rate. Never try to split logs larger than those indicated in the specifications table. This could be dangerous and may damage the machine.

Don't use log splitter for a purpose for which it was not intended.

● **NEVER LEAVE TOOL RUNNING UNATTENDED**

Don't leave tool until it has come to a complete stop.

● **DISCONNECT POWER**

Unplug when not in use, before making adjustments, changing parts, cleaning, or working on the log splitter; Consult technical manual before servicing.

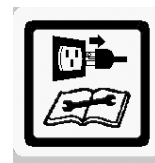

● **PROTECT THE ENVIRONMENT**

Take used oil to an authorized collection point or follow the stipulations in the country where the log splitter is used.

Do not discharge into drains, soil or water.



● **MAINTAIN YOUR LOG SPLITTER WITH CARE**

Keep the log splitter clean for best and safest performance.

● **MAKE THE WORKSHOP CHILDPROOF**

Lock the shop. Disconnect master switches. Store the log splitter away from children and others not qualified to use it.

TABLE OF CONTENTS

Safety Warnings & Cautions	3
Application Conditions	6
Specifications	6
Electrical Requirements	6
Set up and Preparation for Operation	7
Wiring Diagram	8
Plumbing Diagram	8
Log Splitter Operation	9
Freeing a Jammed Log	10
Replacing Hydraulic Oil	11
Sharpening Wedge	11
Trouble Shooting	12
Parts Schematic	13

APPLICATION CONDITIONS

This log splitter is a home use model. It is designed for operating under ambient temperatures between +5°C and 40°C and for installation at altitudes no more than 1000m above M.S.L. The surrounding humidity should less than 50% at 40°C. It can be stored or transported under ambient temperatures between -25°C and 55°C.

SPECIFICATIONS

Model Number		LS5T-37	LS5T-52
Motor		230V~ 50Hz 1500W	IP54
Log Capacity	Diameter	5 ~ 25cm	
	Length	37cm	52cm
Splitting Force		5t	
Hydraulic Pressure		20Mpa	
Hydraulic Oil Capacity		2.4 L	4.2L
Overall Size	Length	780mm	940mm
	Width	260mm	
	Height	480mm	
Weight		38 kg	44kg

The diameter of the log is indicative – a small log can be difficult to split when it has knots or a particularly tough fiber. On the other hand, it may not be difficult to split logs with regular fibers even if its diameter exceeds the max. figure indicated above.

ELECTRICAL REQUIREMENTS

Connect the main leads to a standard 230V \pm 10% (50Hz \pm 1Hz) electrical supply which has protection devices of under-voltage, over-voltage, over-current as well as a residual current device (RCD) which maximum residual current rated at 0.03A.

SET UP AND PREPARATION FOR OPERATION

1. Bolt the Support Leg to the Log Splitter, lift the log splitter by the handles at both ends and place it on a 60 – 75cm high, stable, flat and level work surface.
2. Familiarize yourself with the controls and features of this log splitter in the illustrations.

1. Log Pusher
2. Work Table
3. Wedge
4. Lift Handle
5. Support Leg
6. Log Retaining Plates
7. Switch
8. Motor
9. Pushbutton Box
10. Wheels for Minor Moving ONLY.
11. Hydraulic Control Lever
12. Control Lever Guard
13. Bleed Screw
14. Oil Drain Bolt w/ Dipstick

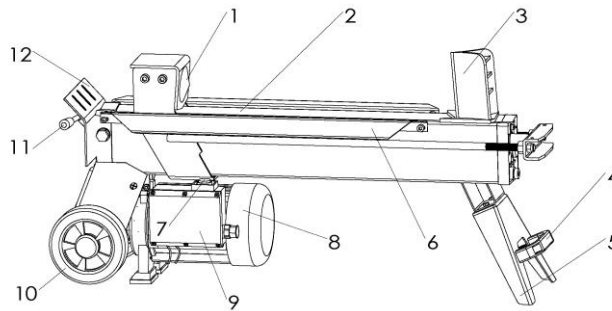

Before operating the log splitter, the Bleed Screw should be loosened by some rotations until air can go in and out of the oil tank smoothly.

Air flow thru the Bleed Screw hole should be detectable during the log splitter is under operations.

Before moving the log splitter, make sure the Bleed Screw is tightened to avoid oil leaking from this point.



FAILED TO LOOSEN THE BLEED SCREW WILL KEEP THE SEALED AIR IN HYDRAULIC SYSTEM BEING COMPRESSED AFTER BEING DECOMPRESSED. SUCH CONTINUOUS AIR COMPRESSION AND DECOMPRESSION WILL BLOW OUT THE SEALS OF THE HYDRAULIC SYSTEM AND CAUSE PERMANT DAMAGE TO THE LOG SPLITTER.

15. Max Pressure Limiting Screw

 **DO NOT ADJUST THE MAX PRESSURE LIMITING SCREW!**

Max pressure was set before the log splitter ex work and the max pressure limiting screw is sealed with glue to ensure the log splitter works under pressure no more than 5 tons. The setting was done by qualified mechanic with professional instruments.

Unauthorized resetting will cause the hydraulic pump fail to output enough splitting pressure or **RESULT IN SERIOUS INJURY AS WELL AS DAMAGE TO THE MACHINE.**

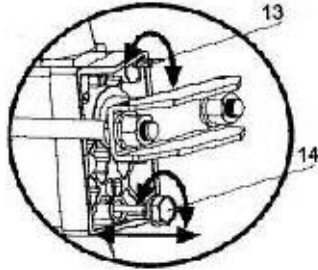

WIRING DIAGRAM

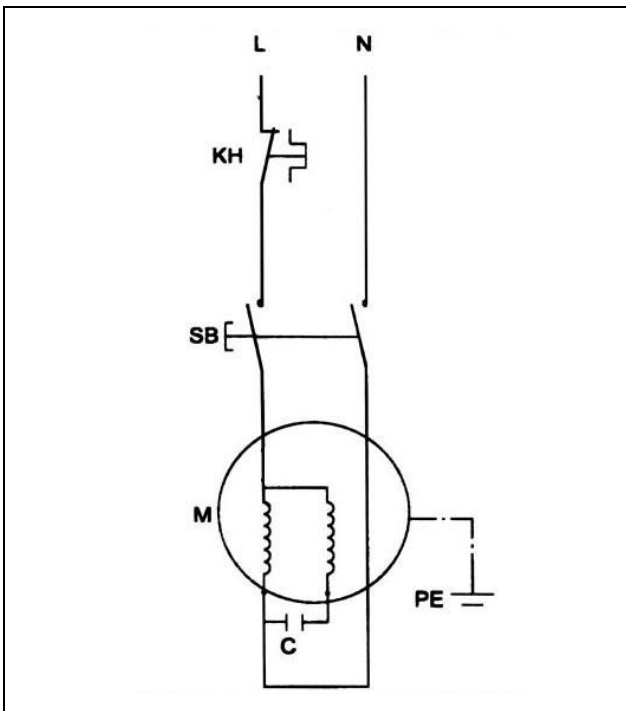

PLUMBING DIAGRAM

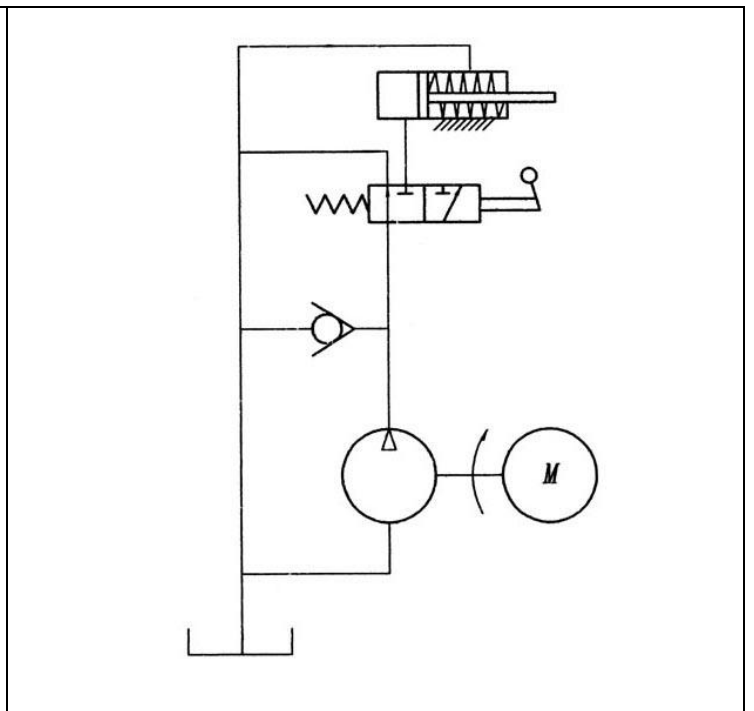

LOG SPLITTER OPERATION

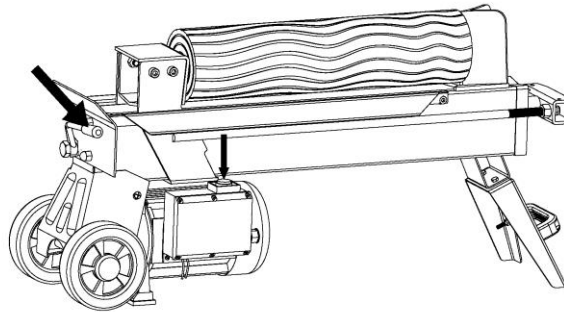

This log splitter is equipped with “ZHB” control system that requires to be operated by both hands of the user – Left hand controls the hydraulic control lever while right hand controls the pushbutton switch. The log splitter will freeze upon absence of either hand. Only after both hands release the controls, the log pusher starts to return backward to the starting position.

Trigger type lock-out device is adopted to avoid accidental Hydraulic Control Lever pushdown. To operate the Hydraulic Control Lever, draw the Trigger backward with the index finger before push the Hydraulic Control Lever forward.



Never force the log splitter for more than 5 seconds by keeping pressure on it to split excessively hard wood.

After this time interval, the oil under pressure will be overheated and the machine could be damaged. For such extremely hard log, rotate it by 90° to see whether it can be split in a different direction. In any case, if you are not able to split the log, this means that its hardness exceeds the capacity of the machine and thus that log should be discarded to protect the log splitter.

Always set logs firmly on the log retaining plates and work table. Make sure logs will not twist, rock or slip while being split. Do not force the blade by splitting the log on the upper part. This will break the blade or damage the machine.

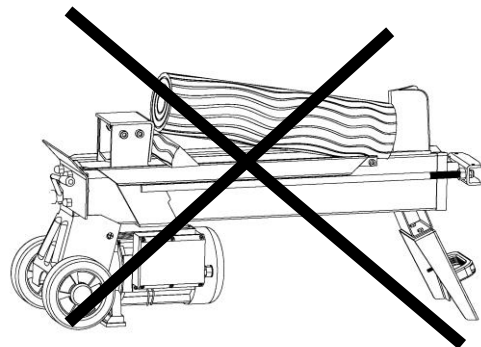

Break log in the direction of its growing grain. Do not place log across the log splitter for splitting. It may be dangerous and may seriously damage the machine.

Do not attempt to split 2 pieces of logs at the same time. One of them may fly up and hit you.

FREEING A JAMMED LOG

- Release both controls.
- After the log pusher moves back and completely stops at its starting position, insert a wedge wood under the jammed log.
- Start the log splitter to push the wedge wood to go completely under the jammed one.
- Repeat above procedure with sharper slope wedge woods until the log is completely freed.

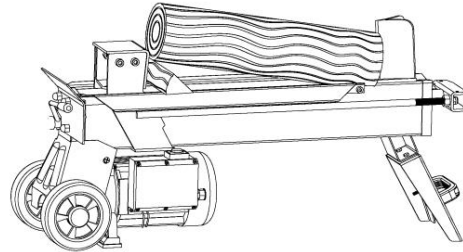

Do not try to knock the jammed log off. Knocking about will damage the machine or may launch the log and cause accident.

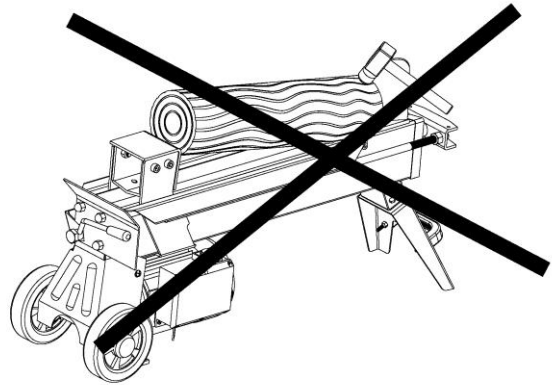

REPLACING HYDRAULIC OIL

Replace the Hydraulic oil in the log splitter after every 150 hours of use. Take following steps to replace it.

- Make sure all moving parts stops and the log splitter is unplugged.
- Unscrew Oil Drain Bolt with Dipstick to remove it.
- Turn the log splitter on the Support Leg side over an 4 liters capacity container to drain the hydraulic oil off.
- Turn the log splitter on the the motor side.
- Refill fresh hydraulic oil at the volume as per the hydraulic oil capacity of a particular model indicated in above specifications table.
- Clean the surface of Dipstick on the Oil Drain Bolt and put it back into the oil tank while keep the log splitter vertically.
- Make sure the level of the refilled oil is just between 2 grooves around the Dipstick.
- Clean the Oil Drain Bolt before thread them back. Make sure they are tightened to avoid leakage before place the log splitter horizontally.

Periodically check oil level to ensure it is between 2 grooves around the Dipstick. Upon Lower oil level, oil refilling is required.

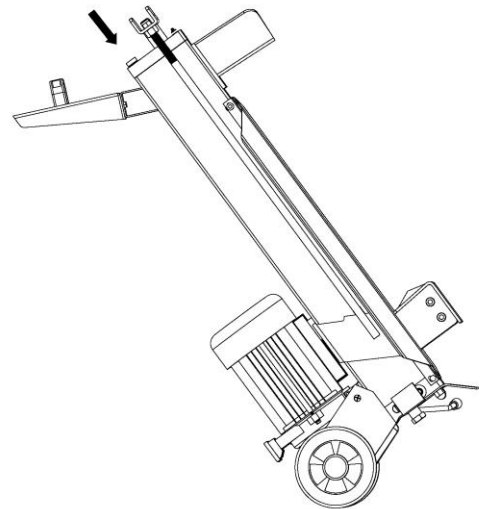
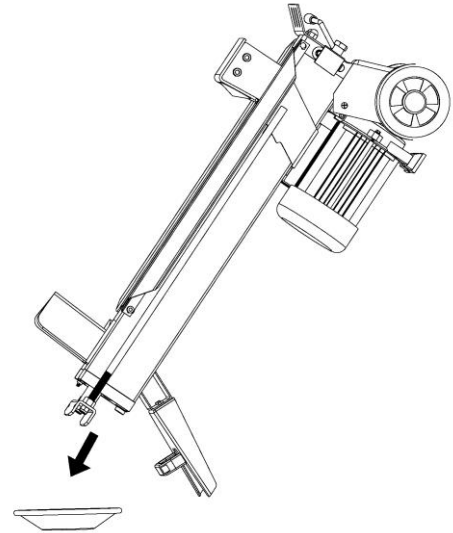

Following hydraulic oils or equivalent are recommend for the log splitter’s hydraulic transmission system:

SHELL Tellus 22

MOBIL DTE 11

ARAL Vitam GF 22

BP Energol HLP-HM 22

SHARPENING WEDGE

After using the log splitters for some time, sharpen the wedge of the log splitter using a fine-toothed file and smooth any burrs or crushed area along the cutting edge.

TROUBLE SHOOTING

PROBLEM	PROBABLE CAUSE	REMEDY SUGGESTED
Motor Stops to Start	Overload Protection Device disengaged to protect the log splitter from being damaged	Contact a qualified Electrician for opening the Pushbutton Box to engage the Overload Protection Device inside *
Fails to split logs	Log is improperly positioned	Refer to “ Log Splitter Operation” section for perfect log loading.
	The sizes or hardness of the log exceeds the capacity of the machine	Reduce the log sizes before splitting it on the log splitter
	Wedge cutting edge is blunt	Refer to “ Sharpening Wedge “ section to sharpen the cutting edge.
	Oil leaks	Locate leak(s) and contact the dealer
	Unauthorized adjustment was made on Max. Pressure Limiting Screw. Lower max pressure rating was set.	Contact the dealer.
The log pusher moves jerkily, taking unfamiliar noise or vibrating a lot	Lack of hydraulic oil and excessive air in the hydraulic system.	Check oil level for possible oil refilling. Contact the dealer.
Oil leaks around cylinder ram or from other points.	Air sealed in hydraulic system while operating.	Loosen Bleed Screw by 3 ~ 4 rotations before operating the log splitter
	Bleed Screw is not tightened before moving the log splitter.	Tighten the Bleed Screw up before moving the log splitter.
	Oil Drain Bolt with Dipstick is not tight.	Tighten the Oil Drain Bolt with Dipstick.
	Hydraulic Control Valve Assembly and / or seal(s) worn	Contact the dealer



Waste electrical products should not be disposed of with household waste,

please recycle where facilities exist, check with your local authority or

